

Strategies for Future Neutrino Experiments: Remarks on Neutrino Sources and Detectors

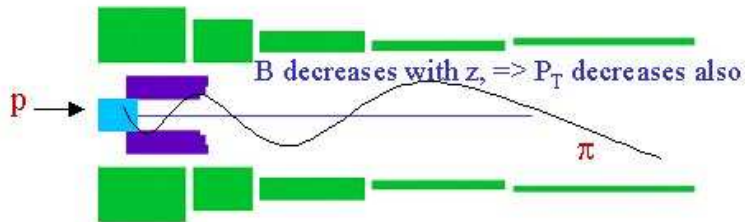

- 1- TOP END CAP IRON YOKE
- 2- BOTTOM END CAP IRON YOKE
- 3- BARREL IRON RETURN YOKE
- 4- COIL
- 5- CRYOSTAT
- 6- CATHODES (N° 5)
- 7- WIRE CHAMBERS (N° 4)
- 8- FIELD SHAPING ELECTRODES

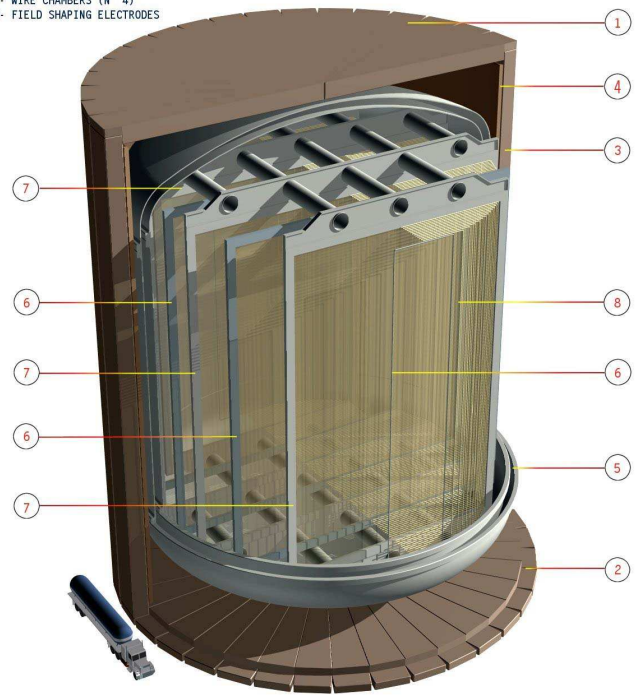

LANNOO
Liquid Argon Neutrino and Nucleon Decay Detector

Kirk T. McDonald

Princeton U.

kirkmcd@princeton.edu

Neutrinos and Implications for Physics

Beyond the Standard Model

Stony Brook, NY, October 13, 2002

<http://puhep1.princeton.edu/~mcdonald/nufact/>

Post-Nobel Opportunities

Data from atmospheric and solar neutrino experiments
 \Rightarrow Rich follow-up physics at accelerators and reactors.

Parameter	Atmos.	Solar	Accel.	Reactor	β Decay
$ \Delta M_{23}^2 $	ID		<i>PM</i>		
θ_{23}	ID		<i>PM</i>		
$ \Delta M_{12}^2 $		ID	<i>PM</i>	<i>PM</i>	
$\text{Sign}(\Delta M_{12}^2)$		ID = PM			
θ_{12}		ID	<i>PM</i>	<i>PM</i>	
ν_{sterile}			<i>ID, PM</i>		
$\text{Sign}(\Delta M_{23}^2)$			<i>ID = PM</i>	<i>ID = PM</i>	
θ_{13}			<i>ID, PM</i>	<i>ID</i>	
Δ_{CP}			<i>ID, PM</i>		
M_ν					<i>ID</i>

(ID = Initial Discovery, PM = Precision Measurement)

No evidence for proton decay, “theories” apparently not falsifiable,
 \Rightarrow Linkage with neutrino expts. should be driven by the latter.

Visions of Grandeur

If CP violation is measurable in the neutrino sector, it will require a very substantial effort.

Three grand visions (each on 3 continents \Rightarrow 9 giant expts.):

1. 1-4 MW Superbeams (ν_μ from π decay) + 0.1-1 Mton detectors [limited to $\sin^2 2\theta_{23} \gtrsim 0.005$ by ν_e in beam] (\$0.5-1.5B).
2. β beams ($\bar{\nu}_e$ from ${}^6\text{He}$, ν_e from ${}^{19}\text{Ne}$) + 1-Mton detectors (\$1.5B).
3. Neutrino factory ($\mu \rightarrow \nu_\mu \bar{\nu}_e e$) + 0.1-1 Mton detectors (\$2-3B).

Physics case: Must first determine if $\sin^2 2\theta_{13}$ is large enough to justify expense of a grand effort to measure δ_C .

Budget reality: Implementation of these grand visions will require sacrifice of smaller efforts.

\Rightarrow Need success of near-term, mid-sized efforts before launch a big experiment.

Corollary: A megaton proton-decay expt. should be deferred until the linked path to a large accelerator-based neutrino expt. is clear.

Multimegawatt Sources

Rate \propto (neutrino flux) (detector mass).

Cost optimization \Rightarrow Source cost \approx Detector cost.

Cost of 4 MW proton source for neutrino beams is less than cost of a 1 Mton neutrino detector.

\Rightarrow Strong interest in developing 4-MW proton sources for neutrino beams (+ neutron spallation, accelerator production of tritium, accelerator transmutation of radioactive waste, ...)

But, solid targets not viable at 4-MW due to beam heating, thermal shock and radiation damage,

\Rightarrow Free liquid jet target may be the most appropriate.

BNL E-951 is presently exploring feasibility of mercury jet targets (+ other backup options).

Studies of Proton Beam + Mercury Jet

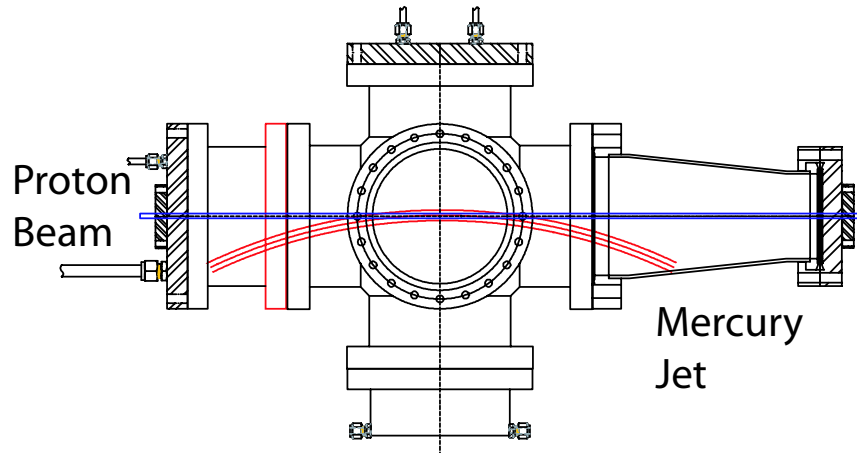

1-cm-diameter Hg jet in 2×10^{12} protons at $t = 0, 0.75, 2, 7, 18$ ms.

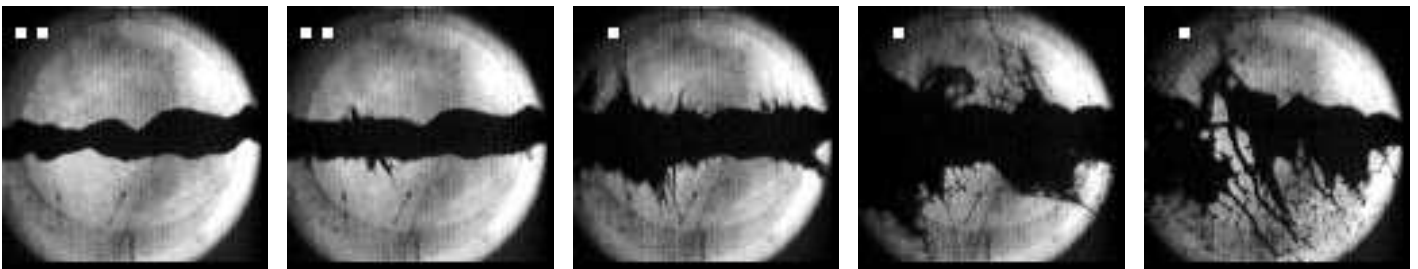

$$\text{Model: } v_{\text{dispersal}} = \frac{\Delta r}{\Delta t} = \frac{r \alpha \Delta T}{r / v_{\text{sound}}} = \frac{\alpha U}{C} v_{\text{sound}} \approx 50 \text{ m/s}$$

for $U \approx 100 \text{ J/g}$.

Data: $v_{\text{dispersal}} \approx 10 \text{ m/s}$ for $U \approx 25 \text{ J/g}$.

$v_{\text{dispersal}}$ appears to scale with proton intensity.

The dispersal is not destructive.

Next step: Mercury jet in beam inside 15-T magnetic field.

The Neutrino Horn Issue

- 4 MW proton beams are achieved in BNL, CERN and FNAL scenarios via high rep rates: $\approx 10^6/\text{day}$.
- Classic neutrino horns based on high currents in conductors that intercept much of the secondary pions will have lifetimes of only a few days in this environment.
- Consider instead a solenoid horn with conductors at larger radii than the pions of interest (*c.f.*, Neutrino Factory Design).
- Adiabatic reduction of the solenoid field along the axis,
 \Rightarrow Adiabatic reduction of pion transverse momentum,
 \Rightarrow Focusing.

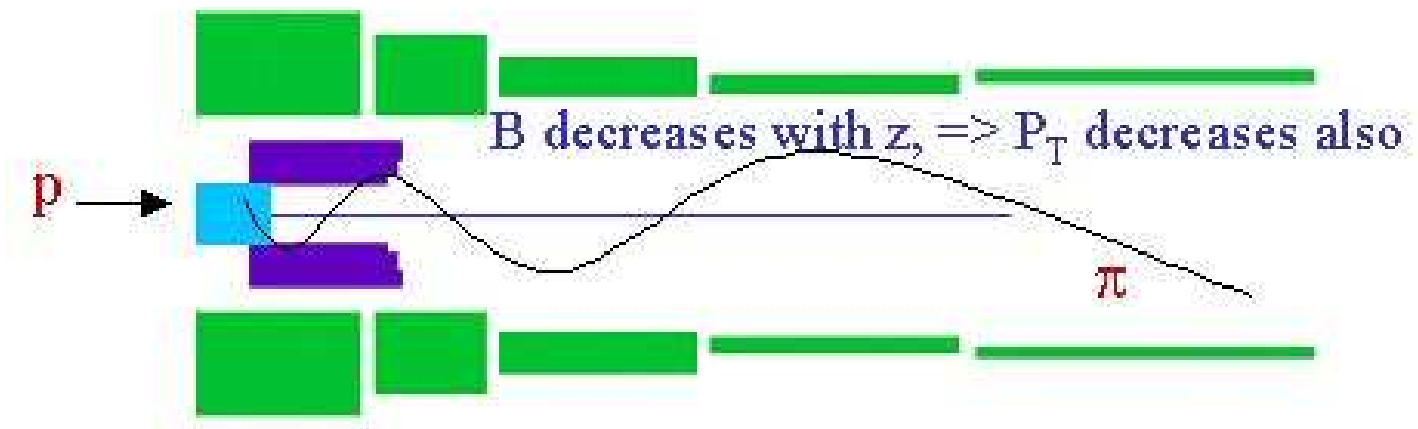

- No sign selection in horn, \Rightarrow Both ν_u and $\bar{\nu}_m u$, \Rightarrow Detector must measure sign of final-state μ or e .

See, <http://pubweb.bnl.gov/users/kahn/www/talks/Homestake.pdf>

Liquid Argon the Best Detector to Study $\sin^2 2\theta_{23}$ in the NUMI Beamline

- ≈ 10 times better per kton than water Čerenkov for $\nu_\mu \rightarrow \nu_e$ appearance at 1-2 GeV (Harris).

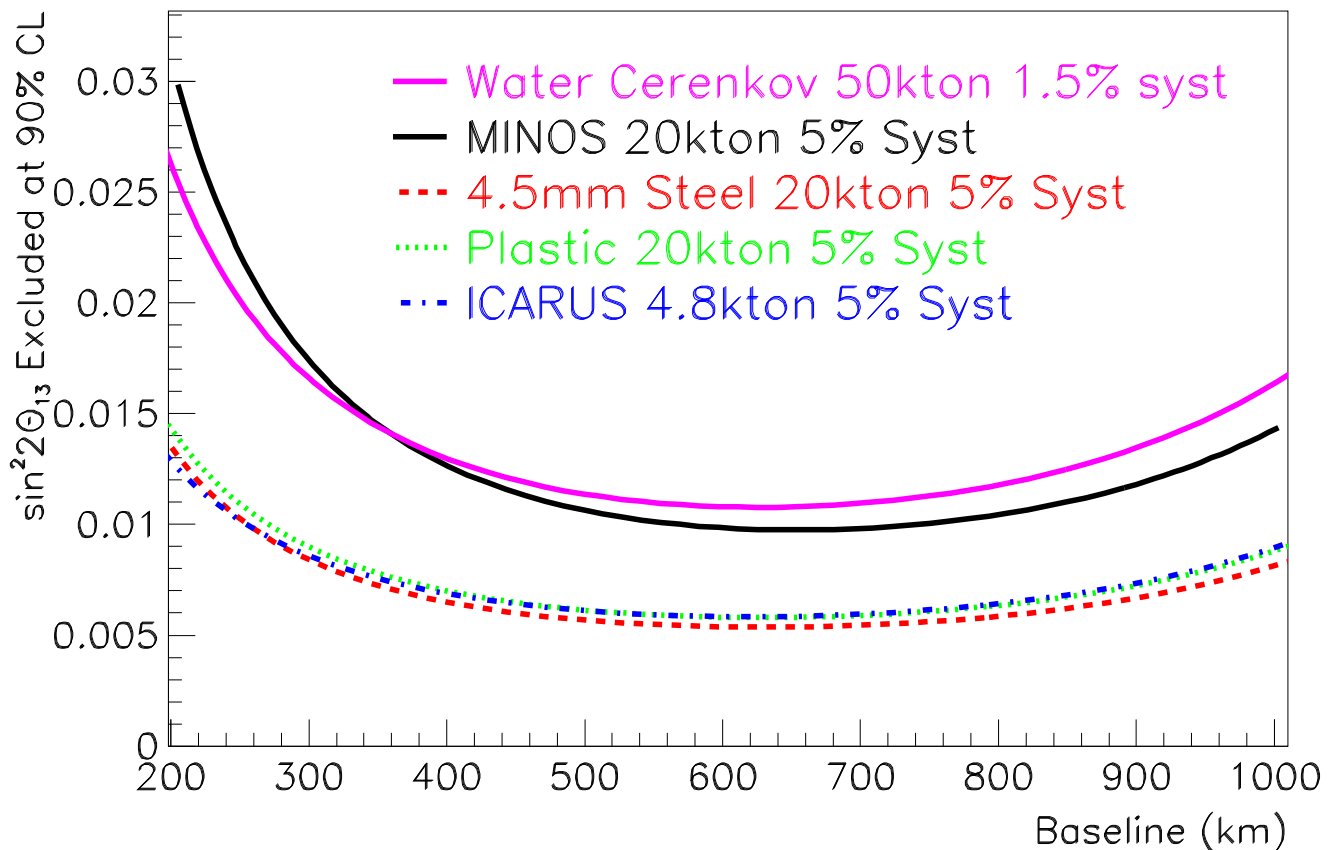

- Density = 1.4; $X_0 = 14$ cm; can drift electrons 2-4 m.
- 100% sampling tracking and calorimetry.
- Construction is simplest of large neutrino detector options.
- Best rejection of neutral current backgrounds, including soft π^0 's.

ICARUS – a Working Liquid Argon Detector

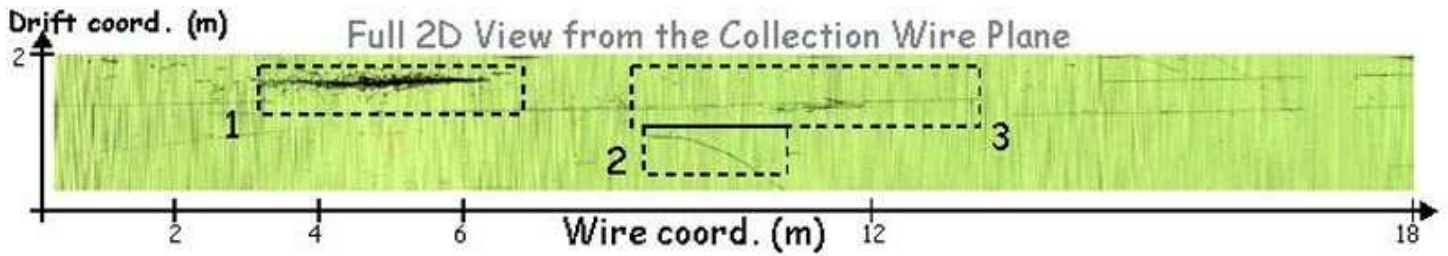

Zoom details

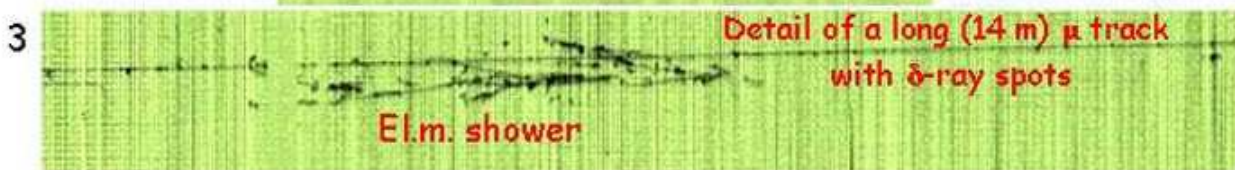
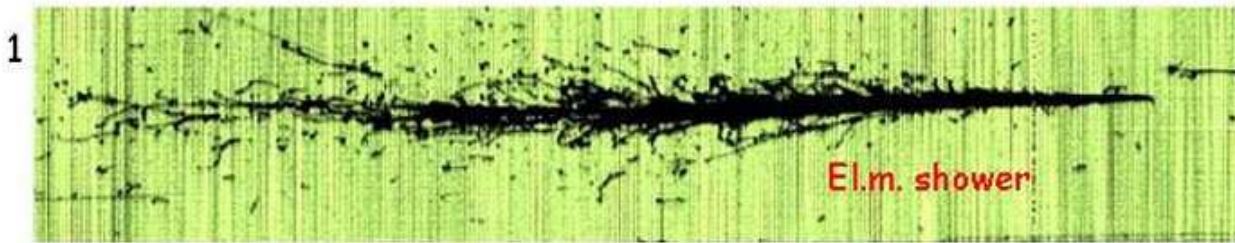

Induction I

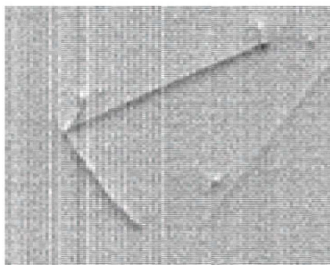

Induction II

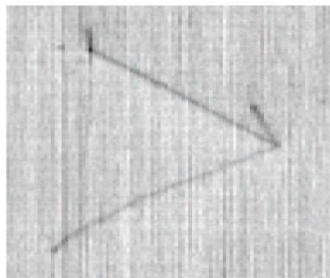

Collection

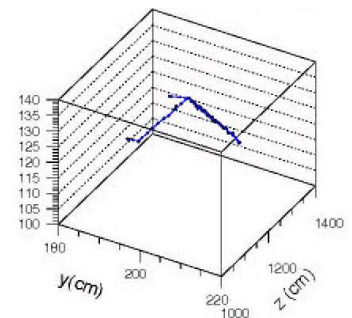
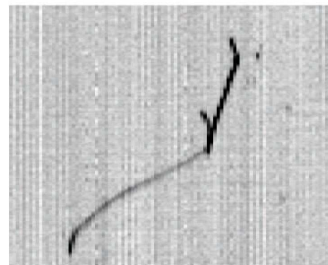

- Operates at the Earth's surface with near zero overlap of cosmic ray events.
- Operates with deadtimeless, selftriggering electronics.

LANNDD – 100 kton Liquid Argon Neutrino and Nucleon Decay Detector

- 1- TOP END CAP IRON YOKE
- 2- BOTTOM END CAP IRON YOKE
- 3- BARREL IRON RETURN YOKE
- 4- COIL
- 5- CRYOSTAT
- 6- CATHODES (N° 5)
- 7- WIRE CHAMBERS (N° 4)
- 8- FIELD SHAPING ELECTRODES

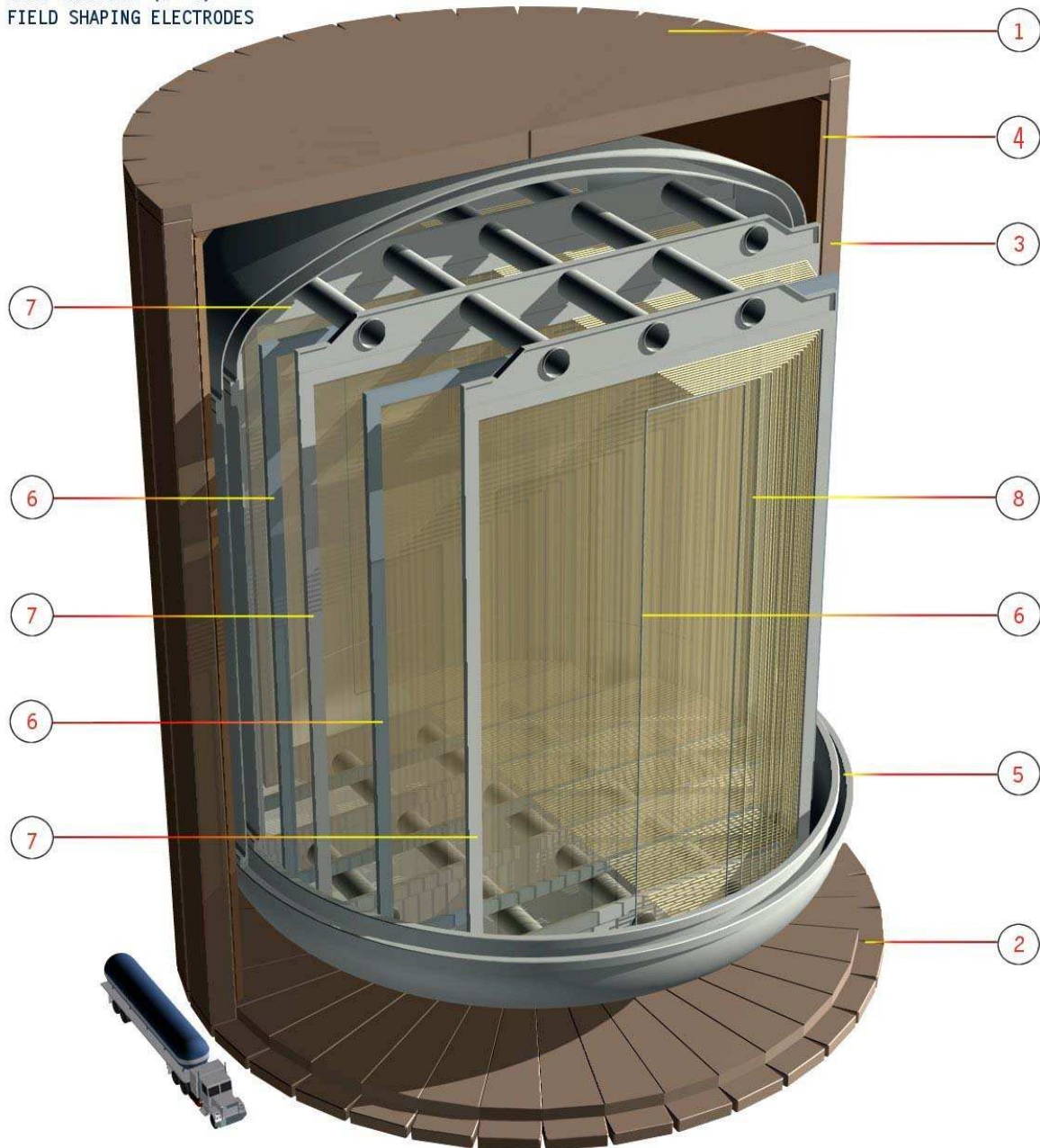

LANNDD
Liquid Argon Neutrino and Nucleon Decay Detector

Is a 100-kton Liquid Argon Detector Feasible?

- Use mature, low-cost technology of liquid methane storage tanks (up to 300 kton based on existing structures).
Preliminary budget estimate from industry of $< \$20\text{M}$ for a 100-kton tank, IF built on the SURFACE.
- 100 kton of liquid argon = 10% of USA annual production.
 \Rightarrow Deliver one trailer-load every 2 hours from Chicago,....
Only 5 ppm O_2 grade available in large quantities,
 \Rightarrow On-site liquid-phase purification via Oxisorb (MG).
Raw material, delivery + purification \Rightarrow $\$0.8\text{M}/\text{kton}$.
- ICARUS electronics from CAEN @ $\$100/\text{channel}$.
3 mm wire spacing \Rightarrow 300k ch \Rightarrow $\$30\text{M}$.
9 mm wire spacing \Rightarrow 100k ch \Rightarrow $\$10\text{M}$.
High capacity of long wires \Rightarrow signal may be too weak to use 3 mm spacing.
- With neutrino beam, record every pulse (10^{-3} duty factor).
Cosmic rays occupy $\approx 10^{-3}$ of active volume,
 $\Rightarrow \approx 10$ MB data per trigger.
 \Rightarrow Modest ($< \$10\text{M}$) DAQ/computer system.

200-kton Cryogenic Tanks Used for LNG Storage

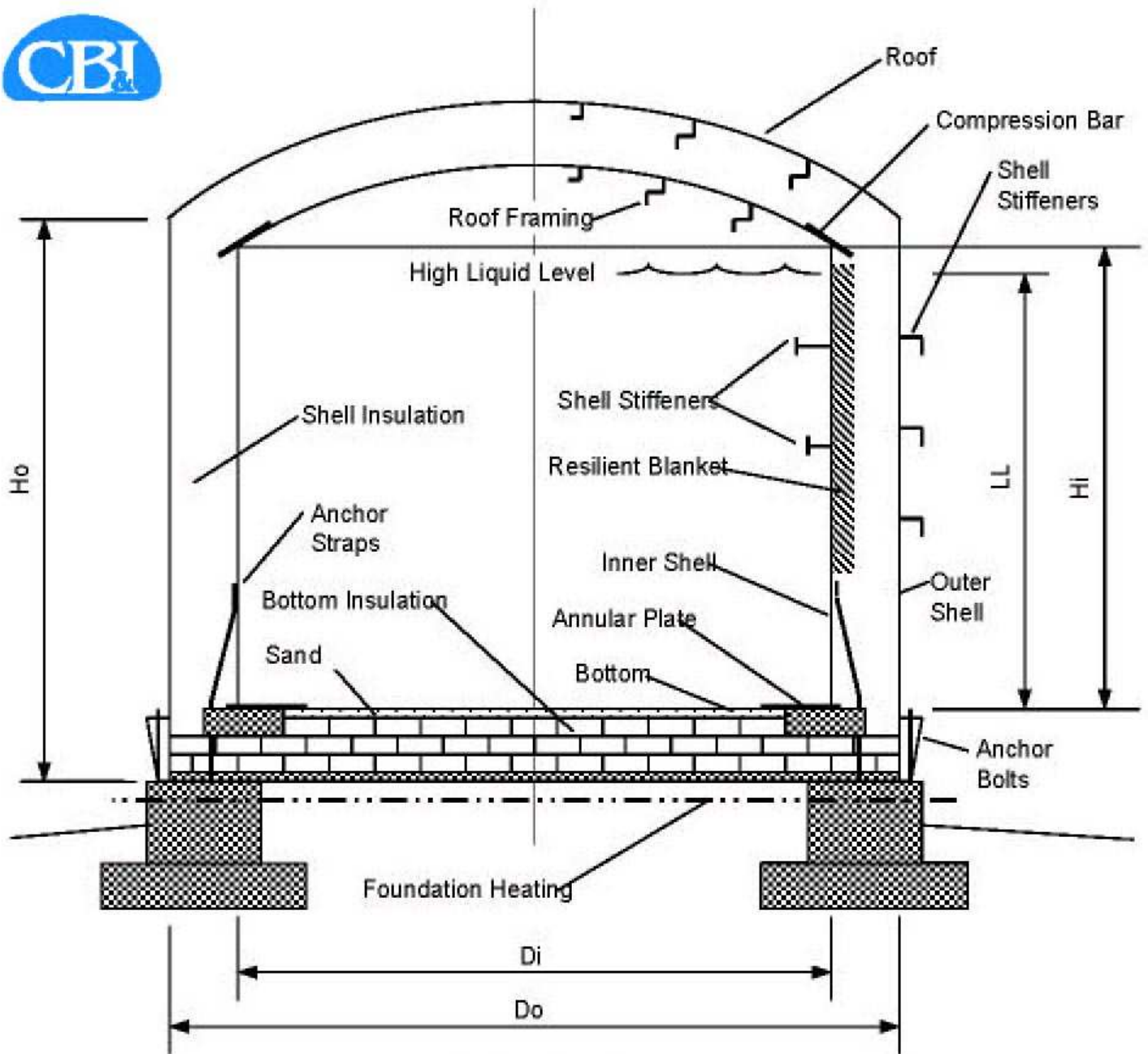

Double Wall & Double Roof Tank

	Feet
Di =	165
Hi =	117.9803
LL =	117.7303
Do =	173
Ho =	118.0443

Chicago Bridge & Iron: can build 100-kton LAr tank for < \$20M.

Cryogenic LNG Storage Tanks

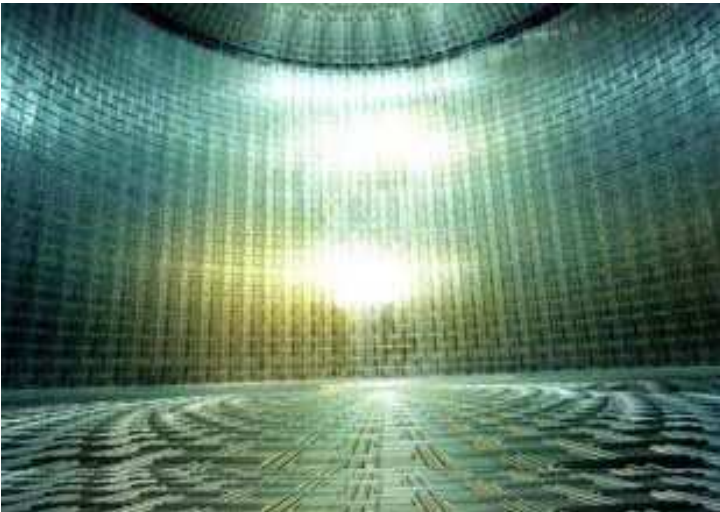

Strong Interest by Praxair

Praxair is the leading USA vendor of liquid argon.

The Praxair R&D Lab in Tonawanda, NY is same Union Carbide lab that provided the expertise to build the Oak Ridge gaseous diffusion plant in the 1940's.

LANNDD Cryogenic System

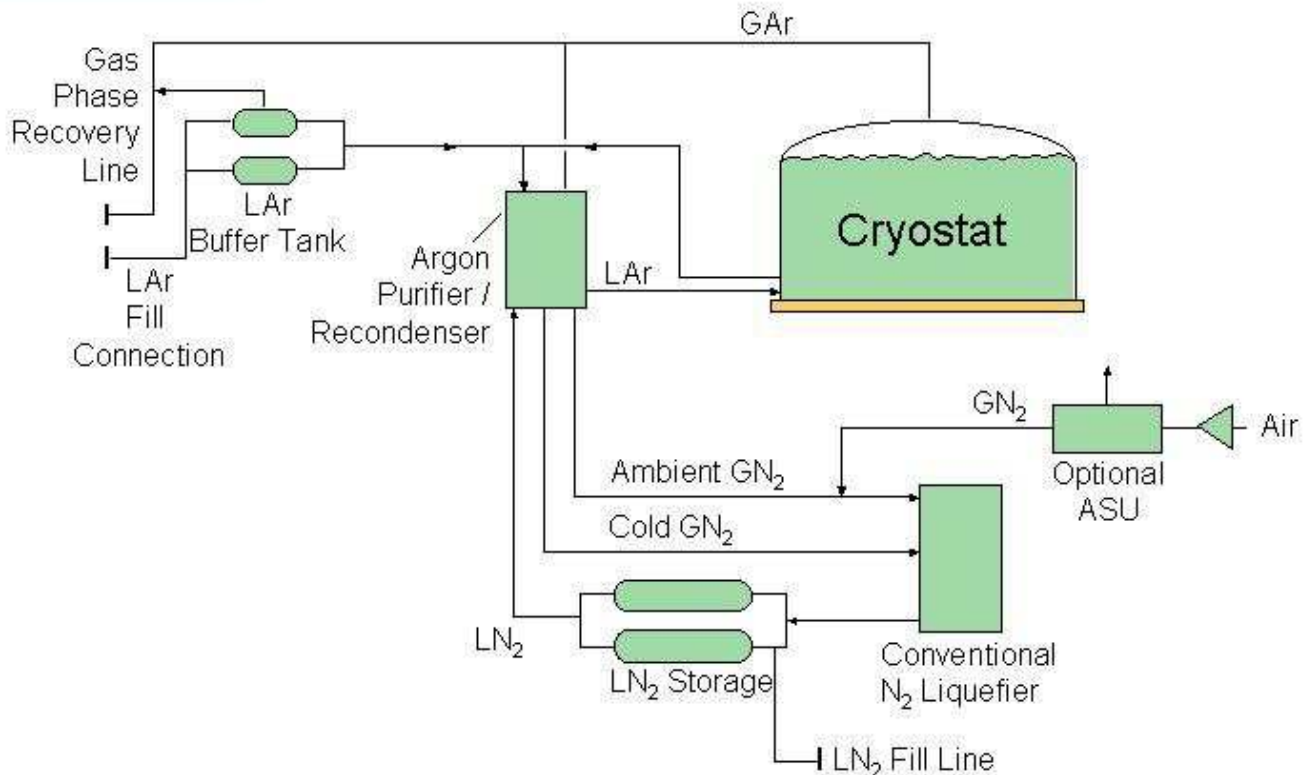

PRAXAIR BUSINESS CONFIDENTIAL

ami:9/2002-CPB 1

100 kton of Liquid Argon as a Detector for $p \rightarrow K^+ \bar{\nu}$

Efficiency for this mode is ≈ 10 times that of water Čerenkov.

This mode favored in many SUSY models.

Can a Proton Decay Search Be Done at the Surface?

- The signature of the decay $p \rightarrow K^+ \bar{\nu}$ is particularly clean:
 $K^+ \rightarrow \pi^+ \rightarrow \mu^+ \rightarrow e^+$.
 \Rightarrow Maybe “no background” to 10^{35} year even at surface.
- Need 100% duty factor for proton decay search.
 $\Rightarrow \approx 10$ GB/sec data rate at surface.
- May need to go underground (100 m?) to suppress the data rate.
 \Rightarrow Additional \$100M to site detector underground.
- Cheaper to buy a big DAQ system and operate at the surface
– if backgrounds are OK there.

Budget Estimate (Very Rough)

For a 100-kton detector at the surface:

Component	Cost
Liquid argon (industrial grade)	\$70M
Cryo plant, including Oxisorb purifiers	\$10M
Surface site preparation	\$10M
Cryogenic storage tank	\$20M
Electronics (300k channels)	\$30M
Computer systems	\$10M
Subtotal	\$150M
Contingency	\$50M
Total	\$200M

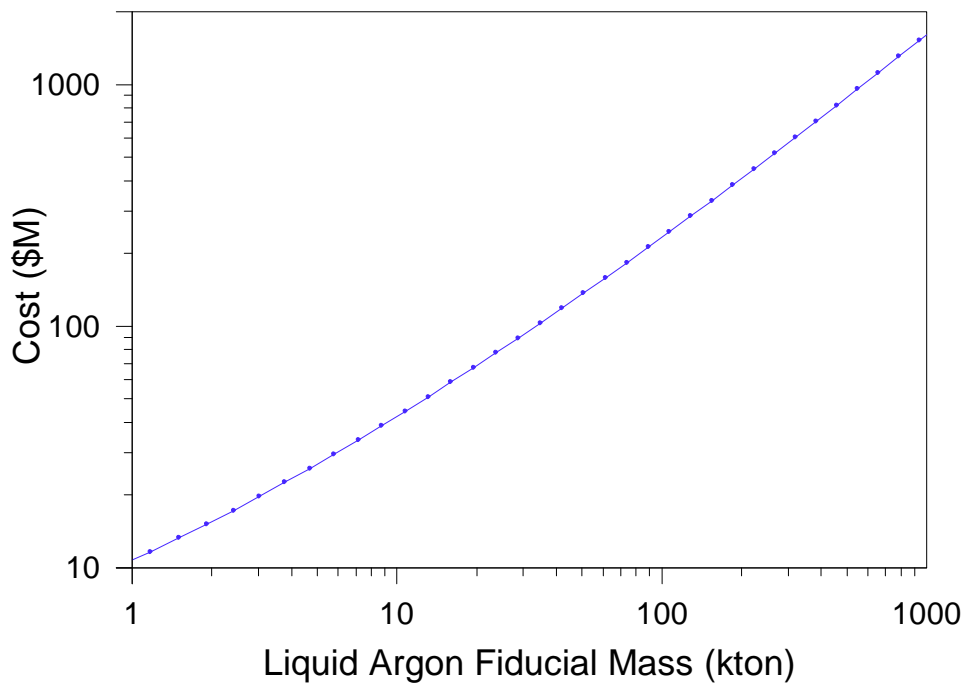

Next Steps

- 40-ton near detector (1.5-ton fid. mass) in off-axis NUMI beam.

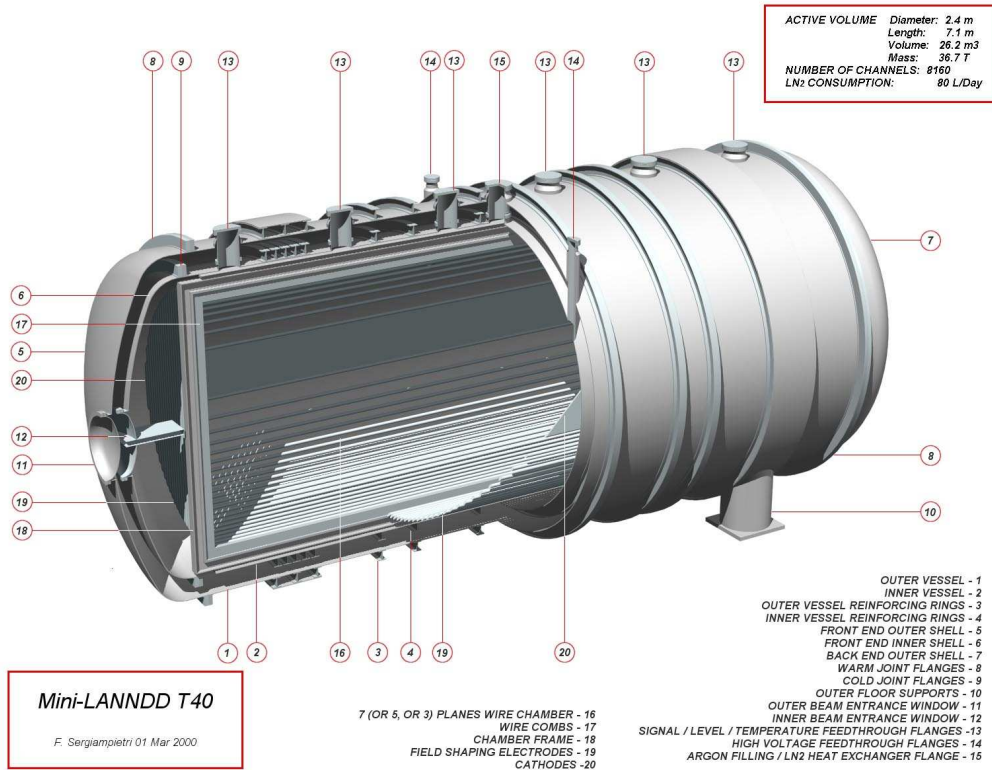

- BNL P-965 to study a liquid argon TPC in a magnetic field.

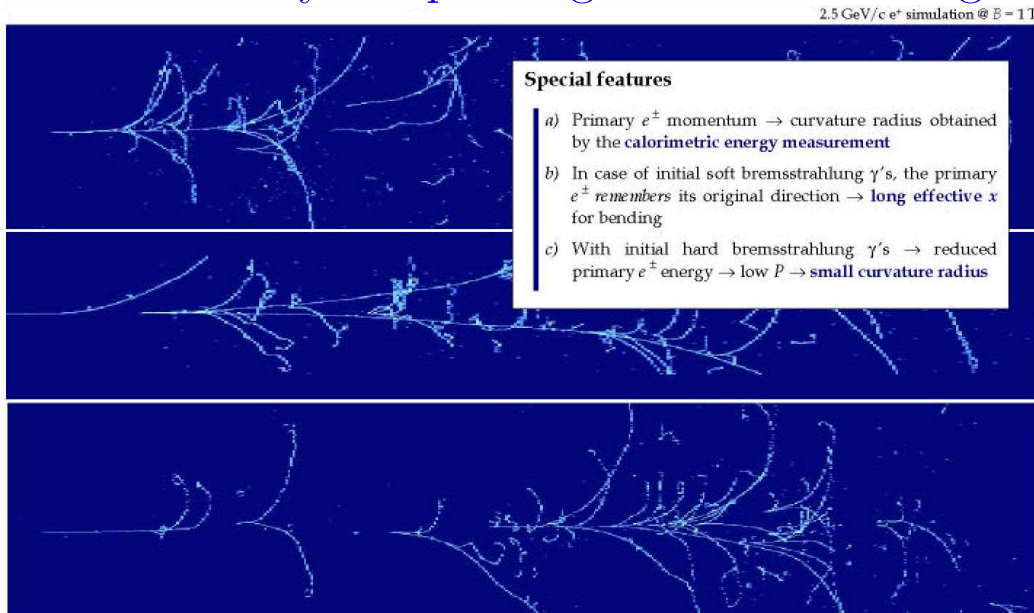

A. Bueno, M. Campanelli, A. Rubbia, IX International Workshop on "Neutrino Telescopes", VENICE, 2001

Should identify sign of e[±] up to ≈ 3 GeV in a 0.5-T field.